



# 240W, 100-277Vac Input Constant Voltage LED Driver



## Constant Voltage Driver

Model: **XV240W24 XYZ HV**  
**XV240W48 XYZ HV**



Model	Input Voltage Range	Output Power	Output Voltage	Output Current Min	Output Current Max	Certification
XV240W24 XYZ HV	180-528Vac	240 W	24V	0	10A	CE
XV240W48 XYZ HV	180-528Vac	240 W	48V	0	5A	CE

XY=	Dimming Method	Programmable	12Vaux	Dim-off	Body Size
NN	-	-	-	-	224.0x67.5x33.5 mm
DN	0-10V	-	-	✓	224.0x67.5x33.5 mm
EN	0-10V	-	✓	✓	224.0x67.5x33.5 mm
AN	DALI	-	-	✓	224.0x67.5x33.5 mm

Z = U, UL cable with ground wire      S, VDE cable/Class I      D, VDE cable/Class II

### 1. Parameters

category	Item	Technical Norm
Features	Output Type	Constant Voltage
	IP Grade	IP67
	Insulation Class	Class II
Input	Input Voltage	90~305Vac or 127V-420Vdc
	Input Frequency	47~63Hz
	Power Factor	>0.9@60-100%load, refer to PF vs. Load curve
	THD	<15%@60-100%load, refer to THD vs. Load curve
	Input Current	1.1Amax@277Vac & Full-Load, 0.65Amax@480Vac & Full-Load
	Inrush Current	65A peak, 1.2ms duration, <0.25A2s@277Vac, Cold Start 70A peak, 1.3ms duration, <0.5A2s@480Vac, Cold Start
	Leakage Current	1mA max @277Vac 60Hz, UL8750,0.75mAmx @240Vac 50Hz, IEC61347-1
	Input Under Voltage	Shut down and auto-restart
	Input Over Voltage	*Optional: Shutdown @320Vac
Surge Protection	Line to line 6kV, line to ground 10kV, IEC 61000-4-5	



## 240W, 100-277Vac Input Constant Voltage LED Driver

Output	Voltage Accuracy	$\pm 3\%V_o$
	Setup Time	1.2s max.
	Output Overshoot	10% $V_o$ , max.
	Output Over Current	120% $I_o$ , typ.
Protection	Short Circuit	Auto recovery. The output recovers when short is removed.
	Over Temperature	Lower the output current when $T_c \geq 105 \pm 10^\circ\text{C}$ ; Auto Recovery When $T_c \leq 70 \pm 10^\circ\text{C}$
Environment	Operating Temperature	$-40^\circ\text{C} \sim +70^\circ\text{C}$ ; 10%RH~100%RH
	Storage Temperature	$-40^\circ\text{C} \sim +85^\circ\text{C}$ ; 5%RH~100%RH
Standards	Certification	CE
	Safety Standards	EN61347-1:2015,EN61347-2-13:2014/A1:2017,EN62493:2015
	EMC Standards	EN55015:2013/A1:2015,EN61000-3-2:2014,EN61000-3-3:2013,EN61547:2009
	Performance	EN62384
Others	MTBF	$\geq 280,000$ hours, $75^\circ\text{C}$ case temperature (MIL-HDBK-217F)
	Lifetime	$\geq 100,000$ hours, $75^\circ\text{C}$ case temperature, refer to life vs. $T_c$ curve
	Case Temperature	$90^\circ\text{C}$ max, marked in the $T_c$ point of label
	Dimension 24V,48V	8.82x2.68x1.51 by inch (body), 9.88x2.68x1.51 by inch (endcaps included)
	Models	224 x 67.5 x 33.5 by mm (body), 251 x 68 x 38.5 by mm (endcaps included)
	Net Weight	1600g
	Packing	16pcs/Cartron/20.2kg, 490 x 370 x 210 by mm
Notes: Unless specified, all the test results are measured in $25^\circ\text{C}$ room temperature. * marked items are optional and contact with sales people to get the functions.		



## 2. Dimming

Parameter	Min.	Typ.	Max.
Vdim Sourcing Current	200uA	300uA	450uA
Vdim Allowed Input Voltage	-20 V		20 V
0-10V Dimming Range	2% (Vdim=1V)	Linear	100% (Vdim=9~10V)
PWM Dimming Range	2% (Duty=10%)	Linear	100% (Duty=90-100%)
Dim off threshold	0.4V or 4%	0.5V or 5%	0.6V or 6%
Dim on threshold	0.6V or 6%	0.7V or 7%	0.8V or 8%
PWM High	3V		10V
PWM Low	0V		0.6V
PWM Frequency	300Hz		2kHz
External PWM Controller Current Sinking Capability	300uA		
DALI Interface Standard		IEC62386	
DA1,DA2 High Level	9.5	16	22.5
DA1,DA2 Low Level	-6.5	0	6.5
DA1,DA2 Current	0		2mA

### - Dimming Curve

0-10V Dimming Curve

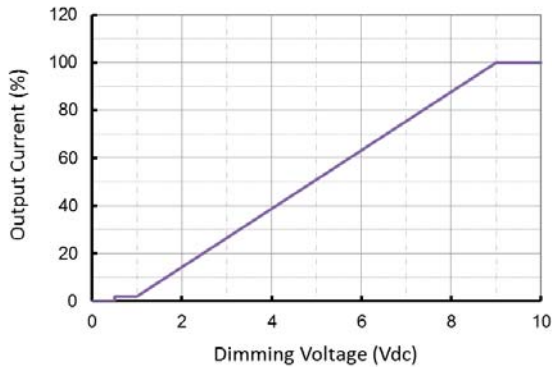

PWM Dimming Curve

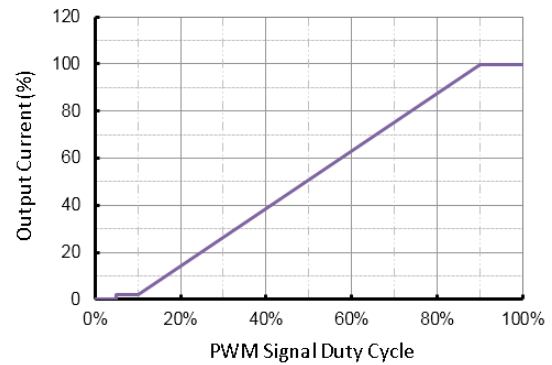

### - Dimming Wiring

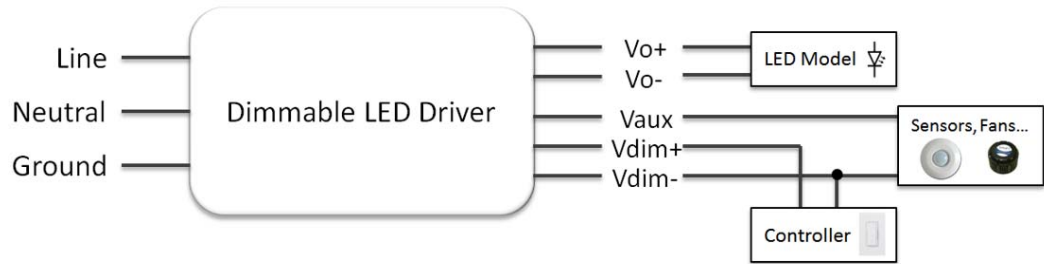

### 3. Lifetime vs. Case Temperature

Lifetime vs. Case Temperature

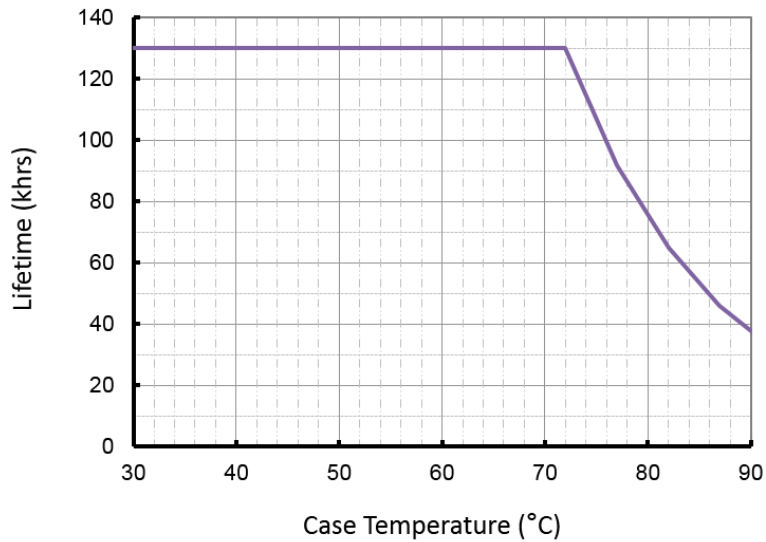

(End of Life: Maximum Failure Rate=10%)

#### 4. Power Factor vs. Load

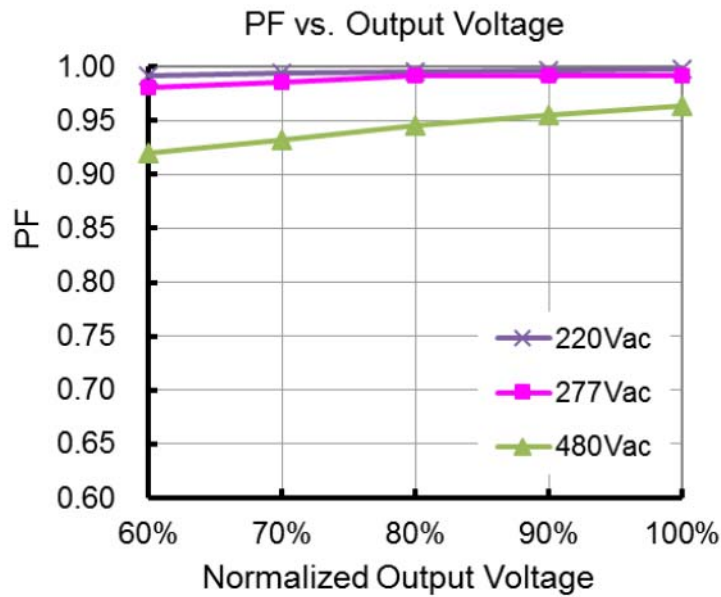

#### 5. THD vs. Load

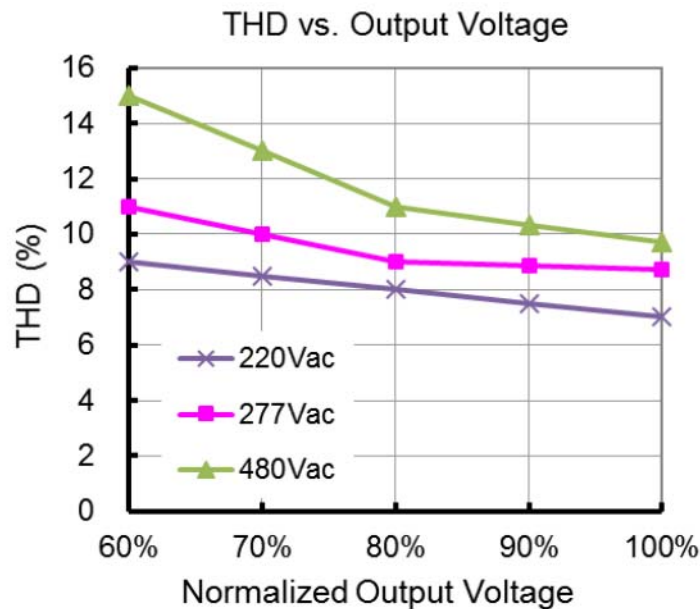

#### 6. Efficiency vs. Load (1.05A Model)

KGP Electronics GmbH  
Hueckstraße 19  
DE-58511 Lüdenscheid

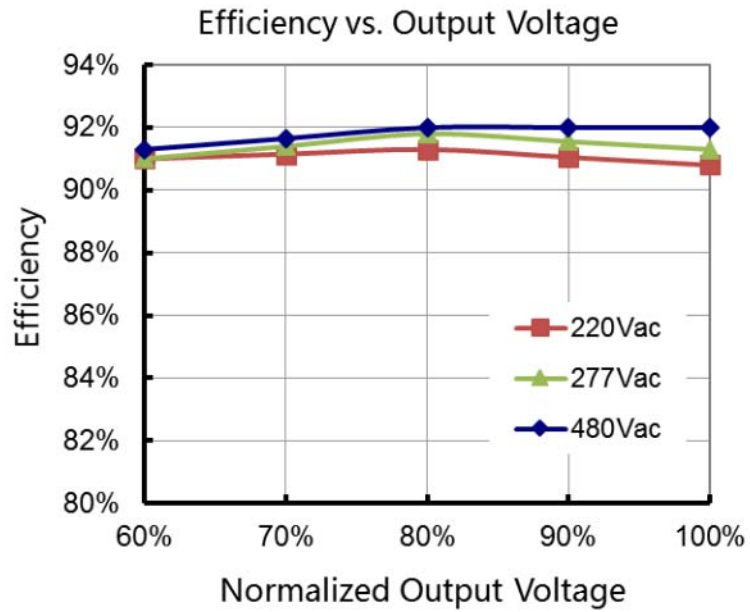

**7. Mechanical Design (for example XV240W24 XYZ HV )**

**- XV240W24 NNU HV(UL Cable)**

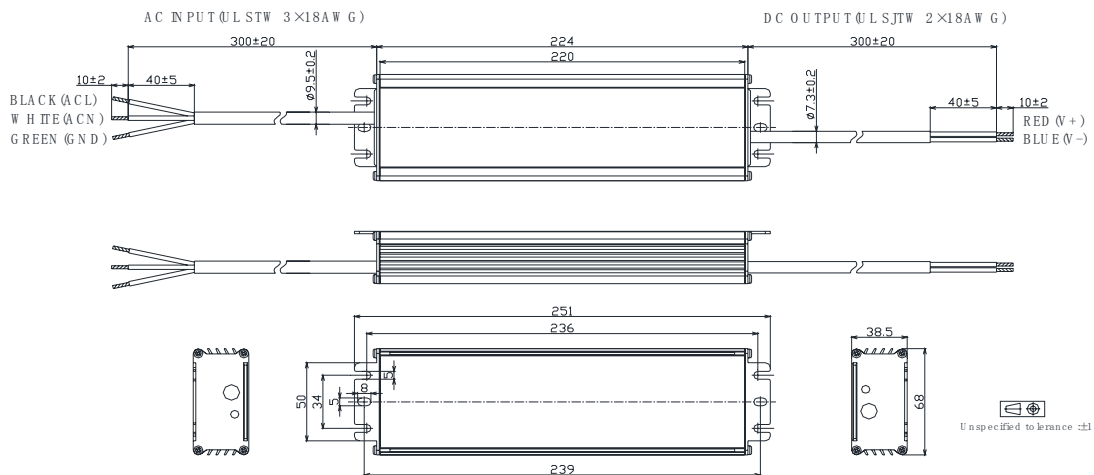

**- XV240W24 ENU HV(UL Cable)**

KGP Electronics GmbH  
 Hueckstraße 19  
 DE-58511 Lüdenscheid





# 240W, 100-277Vac Input Constant Voltage LED Driver

